



DX 5

English

1 Information about the documentation

1.1 About this documentation

- Read this documentation before initial operation or use. This is a prerequisite for safe, trouble-free handling and use of the product.
- Observe the safety instructions and warnings in this documentation and on the product.
- Always keep the operating instructions with the product and make sure that the operating instructions are with the product when it is given to other persons.

1.2 Explanation of symbols used

1.2.1 Warnings

Warnings alert persons to hazards that occur when handling or using the product. The following signal words are used:

DANGER

DANGER !

- ▶ Draws attention to imminent danger that will lead to serious personal injury or fatality.

WARNING

WARNING !

- ▶ Draws attention to a potential threat of danger that can lead to serious injury or fatality.





CAUTION

CAUTION !

- ▶ Draws attention to a potentially dangerous situation that could lead to slight personal injury or damage to the equipment or other property.





1.2.2 Symbols in the documentation

The following symbols are used in this document:

	Read the operating instructions before use.
	Instructions for use and other useful information
	Dealing with recyclable materials
	Do not dispose of electric equipment and batteries as household waste

1.2.3 Symbols in the illustrations

The following symbols are used in illustrations:

	These numbers refer to the corresponding illustrations found at the beginning of these operating instructions
	The numbering reflects the sequence of operations shown in the illustrations and may deviate from the steps described in the text
	Item reference numbers are used in the overview illustrations and refer to the numbers used in the product overview section
	This symbol is intended to draw special attention to certain points when handling the product.
	Wireless data transfer

1.3 Product-dependent symbols

1.3.1 Symbols

The following symbols are also used:

	Warning! Observe the instructions.
	Wear a hard hat while working with the tool.
	Wear protective glasses while working with the tool.
	Wear ear protection while working with the tool.

1.3.2 Symbols on the product

The following symbols are used on the product:

	Black lock on a red background on the tool casing: On the release button for removing the exhaust gas piston return unit.
	White lock on a black background on the fastener guide or on the magazine: On the fastener guide release button.

1.3.3 Information shown on the display

The following information may be shown on the display:

	This symbol indicates the battery's state of charge. When the battery is empty, the maintenance symbol is shown.
	This symbol indicates when the tool requires cleaning. One segment stands for 500 fasteners driven. There are five segments in total, which means that 2500 fasteners can be driven before cleaning is required.
	This symbol indicates when servicing is due. It appears after 5 years, when 30,000 fasteners have been driven, or when the battery is empty. Our recommendation: Please contact Hilti Service .

1.4 Product information

products are designed for professional users and only trained, authorized personnel are permitted to operate, service and maintain the products. This personnel must be specifically informed about the possible hazards. The product and its ancillary equipment can present hazards if used incorrectly by untrained personnel or if used not in accordance with the intended use.

The type designation and serial number are printed on the rating plate.

- ▶ Write down the serial number in the table below. You will be required to state the product details when contacting Hilti Service or your local Hilti organization to inquire about the product.

Product information

Fastening tool	DX 5 DX 5 GR DX 5 SM
Generation	01
Serial no.	

1.5 Declaration of conformity

We declare, on our sole responsibility, that the product described here complies with the applicable directives and standards. A copy of the declaration of conformity can be found at the end of this documentation.

The technical documentation is filed and stored here:

Hilti Entwicklungsgesellschaft mbH | Tool Certification | Hiltistrasse 6 | D-86916 Kaufering, Germany

2 Safety

2.1 Safety instructions

Basic information concerning safety

⚠ WARNING! Read all safety precautions and other instructions. Failure to observe the safety precautions and other instructions may result in electric shock, fire and/or serious injury.

Keep all safety precautions and instructions for future reference.

Using cartridges

- ▶ Use only **Hilti** cartridges or cartridges of equivalent quality.
 - ◄ Use of cartridges of inferior quality in **Hilti** tools may lead to a build-up of unburned powder, which may suddenly explode and cause severe injuries to operators and bystanders. The cartridges must be either verifiably tested by the manufacturer in accordance with EU standard EN 16264 or they must bear the CE conformity marking.

Requirements to be met by users

- ▶ Only authorized, appropriately trained persons may operate or service this tool.

Personal protective equipment

- ▶ You and any other persons in the vicinity must wear suitable eye protection and a hard hat while the tool is in use.
- ▶ Wear ear protectors.
 - ◄ The fastener driving action is initiated by ignition of a propellant charge. Exposure to noise can cause hearing loss.

Personal safety

- ▶ Observe the information printed in the operating instructions concerning operation, care and maintenance.
- ▶ Stay alert, watch what you are doing and use common sense when operating a direct fastening tool. Don't use the tool when you are tired or under the influence of drugs, alcohol or medication. Take a break if you experience pain or feel unwell. A moment of inattention while operating tools may result in serious personal injury.
- ▶ Avoid working in awkward body positions. Make sure you work from a safe stance and stay in balance at all times.
- ▶ Wear non-skid shoes.
- ▶ Never pull back the magazine, fastener guide or fastener by hand.
 - ◄ Under certain circumstances, the tool could be made ready to fire by pulling back the magazine, fastener guide or the fastener by hand. When the tool is ready to fire, fasteners or the piston could be driven inadvertently into parts of the body.
- ▶ Keep the arms slightly bent while operating the tool (do not straighten the arms).
- ▶ Keep other people away from the working area, especially children.

Use and care of direct fastening tools

⚠ WARNING! Danger of fasteners penetrating right through. Before driving fasteners, check to make sure that no one is present behind or below the object into which the fastener is to be driven.

- ▶ Before beginning the work, check the cartridge power level and the power regulator setting.
 - ◄ Carry out a test by driving 2 fasteners into the material you are working on.
- ▶ Use the right tool for the work you are carrying out. Do not use the tool for purposes for which it was not intended. Use it only as directed and when in faultless condition.
- ▶ Use a spall stop / protective cap when the application permits.
- ▶ Never leave a loaded tool unattended.
- ▶ Transport and store the tool in a secured toolbox.
- ▶ Always unload the tool (remove cartridges and fasteners) before cleaning, maintenance, changing the fastener guide, before work breaks and before storing the tool.
- ▶ When not in use, the tool should be unloaded and stored in a locked, dry place where it is inaccessible to children.
- ▶ Check the tool and the accessories for any damage. Check that moving parts function faultlessly, without sticking, and that no parts are damaged.
 - ◄ All parts must be fitted correctly and fulfill all conditions necessary for correct operation of the tool. Damaged parts must be properly repaired or replaced by **Hilti** Service unless otherwise stated in the operating instructions.
- ▶ Before driving fasteners, check that there is no electrical wiring behind the surface into which you want to drive them.

- ▶ Do not attempt to drive fasteners into unsuitable materials.
 - ◀ Unsuitable materials include welded steel and cast steel, cast iron, glass, marble, plastic, bronze, brass, copper, insulating material, hollow brick, ceramic brick, thin sheet metal (< 4 mm) and cellular concrete. Driving a fastener into these materials may cause the fastener to break, shatter or to be driven right through.
- ▶ Pull the trigger only when the tool is fully pressed against the working surface at right angles.
- ▶ When driving fasteners, always hold the fastening tool at right angles to the working surface in order to prevent the fastener being deflected by the surface.
- ▶ Keep the grips dry, clean and free from oil and grease.
- ▶ Do not use the tool in places where there is a risk of fire or explosion unless the tool is specially approved for this type of use.
- ▶ Never drive fasteners into existing holes unless this is recommended by **Hilti** (e.g. DX-Kwik).

Workstation

- ▶ Keep the workplace tidy. Objects which could cause injury should be removed from the working area.
 - ◀ Untidiness in the working area can lead to accidents.
- ▶ Make sure that the working area is well lit and well ventilated.

Mechanical safety rules

- ▶ Do not tamper with or modify the tool or parts of it, especially the piston.
- ▶ Use only fasteners of a type approved for use with the tool.

Thermal safety rules

- ▶ Do not exceed the recommended maximum fastener driving rate.
- ▶ If the tool has overheated, allow it to cool down.
- ▶ Do not dismantle the tool while it is hot. Allow the tool to cool down.
- ▶ Allow the tool to cool down if the plastic cartridge strip begins to melt.

Risk of explosion with cartridges

- ▶ Use only cartridges of a type approved for use with the tool.
- ▶ Remove the cartridge strip from the tool when you have completed the work or before transporting the tool.
- ▶ Never attempt to forcibly remove cartridges from the magazine strip or tool.
- ▶ Store unused cartridges in a secure place where they are not exposed to dampness or excessively high temperatures.

3 Description

3.1 Product overview



- | | |
|---|--|
| ① Exhaust gas piston return unit | ⑭ Piston |
| ② Guide sleeve | ⑮ Fastener guide |
| ③ Casing | ⑯ Fastener guide release button |
| ④ Cartridge guideway | ⑰ Buffer |
| ⑤ Power regulation wheel release button | ⑱ Magazine cover |
| ⑥ Power regulation wheel | ⑲ Magazine cover release button |
| ⑦ Display | ⑳ Magazine |
| ⑧ Pushbutton | ㉑ Load status indicator |
| ⑨ Hand pad | ㉒ Interchangeable fastener guide nosepiece |
| ⑩ Trigger | ㉓ Flat brush |
| ⑪ Operating button | ㉔ Large round brush |
| ⑫ Air vents | ㉕ Small round brush |
| ⑬ Piston rings | |

3.2 Intended use

The product described is a fastening tool for use in applications in which nails, threaded studs and combination fasteners are driven into concrete, steel and sand-lime block.

When using the tool, always ensure that the correct equipment is used. The fastener guide, magazine, piston and fasteners must be compatible with one another.

3.3 Cartridges

All Hilti cartridges for powder-actuated tools have been tested successfully in accordance with EN 16264. These tests are carried out by the certification authorities using specific combinations of cartridges and tools. The tool designation, the name of the certification authority and the system test number are printed on the cartridge packaging.

Ordering designation	Color	Power level
6.8/11 M green	green	light
6.8/11 M yellow	yellow	medium
6.8/11 M red	red	heavy
6.8/11 M black	Black	extra heavy

3.4 Minimum distances and spacing

3.4.1 Fastening to concrete

Always observe the following minimum distances and spacing when fastening to concrete:

- The minimum distance from the edge of the working surface to the fastener must be at least 70 mm.
- The minimum center-to-center distance between two fasteners must be at least 80 mm.
- The working surface must be at least 100 mm thick.

3.5 Information about the app

To obtain more information (if available) about the app, download the app and start it, scan the QR code in the case.

3.6 Information about the field of applications

Please refer to the Hilti product page for more information about the field of applications.

4 Technical data

4.1 Direct fastening tool

Weight	DX 5	3.37 kg
Tool length	DX 5	478 mm
Nail length	DX 5	≤ 72 mm

Recommended maximum fastening rate	DX 5	700 rev/h
Application temperature (ambient temperature)	DX 5	-20 °C ...50 °C
Compression stroke	DX 5	32 mm
Pressure required	DX 5	≥ 174 N
Maximum emitted transmission power		-27.2 dBm
Frequency		2,400 MHz ...2,483.5 MHz

4.2 Noise information determined in accordance with EN 15895

The sound pressure and vibration values given in these instructions have been measured in accordance with a standardized test and may be used to compare one fastening tool with another. They may be used for a preliminary assessment of exposure. The data given represents the main applications of the fastening tool. However, if the fastening tool is used for different applications, with different accessories or is poorly maintained, the data may vary. This may significantly increase exposure over the total working period. An estimation of the level of exposure should also take into account the periods of time when the tool is not actually in use. This may significantly reduce exposure over the total working period. Prescribe additional safety measures to protect the operator from the effects of noise and/or vibration, such as: Maintenance of the direct fastening tool and its additional equipment or accessories, keeping the operator's hands warm, organization of work procedures.

The noise values listed were determined under the following conditions:

Noise information conditions

Cartridge	6.8/11 caliber, black
Power setting	2
Application	Fastening 24 mm wood to concrete (C40) with X-U47 P8

Noise information in accordance with EN 15895

Sound (power) level (L_{WA})	105 ±2 dB
Emission sound pressure level (L_{pA})	101 ±2 dB
Peak sound pressure emission level (L_{pCpeak})	133 ±2 dB

4.3 Vibration

The vibration value that must be specified in accordance with 2006/42/EC does not exceed 2,5 m/s².

5 Operation

5.1 Safety devices



Before commencing work, check that all safety devices are fitted and that they are functioning correctly. All parts must be fitted correctly and fulfill all conditions necessary for the correct operation of the tool.

5.2 Loading the single-fastener tool

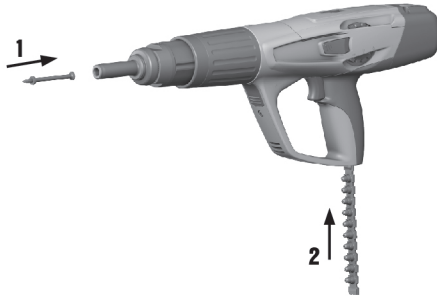

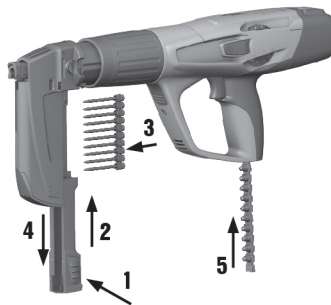

1. Push the fastener into the tool from the front until it is held in place in the tool by the fastener's washer.
2. Push the cartridge strip, narrow end first, into the grip of the tool from below until the full length of the cartridge strip is inside the tool. If you wish to use a cartridge strip in which some of the cartridges have already been used, start pulling the strip up and out the top of the tool by hand until the first unused cartridge is in place in the cartridge chamber.

5.3 Loading the magazine tool



1. Pull the magazine cover down and insert the fastener strip (strip of ten) in the tool.
2. Push the cartridge strip, narrow end first, into the grip of the tool from below until the full length of the cartridge strip is inside the tool. If you wish to use a cartridge strip in which some of the cartridges have already been used, start pulling the strip up and out the top of the tool by hand until the first unused cartridge is in place in the cartridge chamber.

 If the loading status indicator is partly or completely red, there are 3 or less fasteners in the magazine. The magazine may then be reloaded with a strip of ten nails.

 All fasteners in the magazine must be of the same length.

5.4 Setting the power level

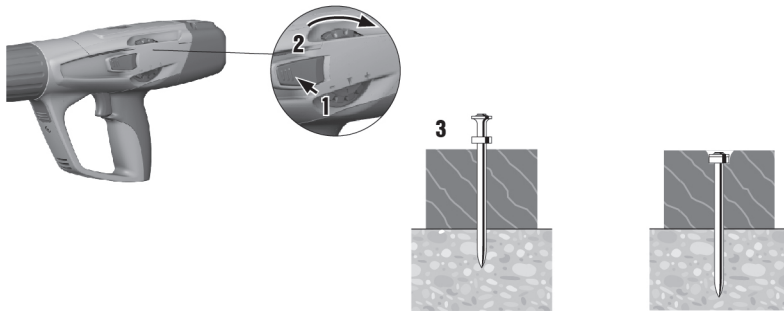

1. Press the power regulator release button.
2. Turn the power regulating wheel to set the power level you require.
3. Check the quality of the fastening in accordance with **Hilti** standards.

i Select a cartridge power level and power setting to suit the application.
If you have no previous experience of using the tool, always begin with the lowest power.

5.5 Driving fasteners with the single-fastener tool

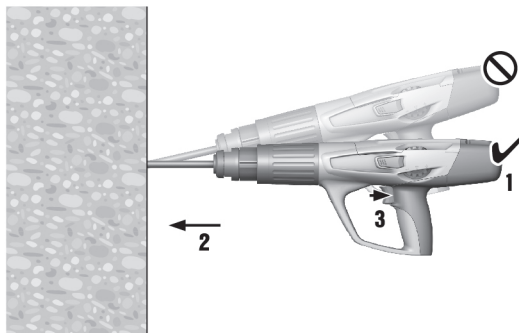

1. Position the tool.
2. Hold the tool perpendicular to the working surface and then press it against the surface.
3. Press the trigger to drive the fastener.

5.6 Driving fasteners with the magazine tool

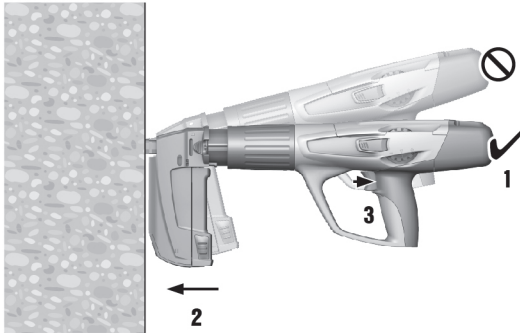

1. Position the tool.
2. Hold the tool perpendicular to the working surface and then press it against the surface.
3. Press the trigger to drive the fastener.

5.7 Unloading the single-fastener tool



1. Pull the cartridges out of the tool.
2. Pull the fastener out of the tool.

5.8 Unloading the magazine tool



1. Pull the cartridges out of the tool.
2. Pull the magazine cover down and remove the fastener strip.

5.9 Resetting the cleaning indicator

- ▶ Press and hold the pushbutton for 10-12 seconds to reset the cleaning indicator.



The cleaning indicator consists of 5 bars. Each bar stands for 500 fastenings.

5.10 Procedure if a cartridge fails to fire

1. Keep the nose of the tool pressed at right angles against the working surface for 30 seconds.
2. If the cartridge still fails to fire, lift the tool away from the working surface. Take care to avoid pointing it at yourself or other persons.
3. Pull the cartridge strip by hand to advance it to the next cartridge and use up the remaining cartridges on the strip.

5.11 Tool misfires (cartridge doesn't fire)



WARNING

Heat The tool can get hot through use.

- ▶ Wear protective gloves.
- ▶ Allow the tool to cool down.

1. Stop using the tool immediately.
2. Unload and dismantle the tool.
3. Check that you are using the correct combination of magazine, piston and fasteners.
4. Check the buffer, piston and magazine for wear, and replace the parts if necessary.
5. Clean the tool.
 - ◀ If the problem persists after taking the measures described above, further use of the tool is not permissible.
 - ◀ Have the tool checked and, if necessary, repaired by **Hilti Service**.



Dirt and residues build up in the tool under normal operating conditions and functional parts are also subject to wear.

Carry out regular inspections and servicing. Servicing must be carried out after 30,000 fasteners have been driven.

Clean the tool after every 2,500 - 3,000 fastenings. The fastener counter shows how many fasteners have been driven since the cleaning indicator was last reset. One bar stands for 500 fasteners.

Check the piston and the buffer daily when the tool is subjected to intensive use, or at the very least, before the end of the recommended regular cleaning interval of 2,500 - 3,000 fastenings.

The inspections, service intervals and cleaning intervals are based on typical tool use. If you find that the tool is not functioning correctly before a scheduled interval is reached, service the tool immediately.

6 Care and maintenance

6.1 Care of the tool



WARNING

Cleaning Pay attention to the following points when cleaning the tool:

- ▶ Do not clean with a spray system or pressure jet washer.
- ▶ Do not permit foreign objects to enter the interior of the tool.

WARNING

Risk of injury due to deflagration Powder residue in the tool may ignite and cause uncontrolled triggering or fragmentation.

- ▶ Clean the tool regularly. Comply with all maintenance and cleaning information and instructions in this documentation.
 - ▶ If inferior-quality cartridges are used, cleaning the tool will not reduce the risk of powder residue inside the exhaust gas piston return unit igniting and causing uncontrolled triggering or fragmentation. This can only be reduced by having the tool taken to **Hilti Service** for maintenance.
-
- ▶ Clean the exterior of the tool with a slightly damp cloth at regular intervals.

6.2 Maintenance

WARNING

Dangerous substances The deposits inside DX tools contain substances that may present a health hazard.

- ▶ Do not inhale dust or dirt while cleaning.
 - ▶ Keep dust and dirt away from foodstuffs.
 - ▶ Wash your hands after cleaning the tool.
 - ▶ Never use grease to clean or lubricate tool components. This may lead to malfunctions. To avoid malfunctions caused by the use of unsuitable cleaning agents, use **Hilti spray**.
-

1. Regularly check all external parts of the tool for damage.
2. Regularly check all operating controls to ensure that they work properly.
3. Use the tool only with the recommended cartridges and at the recommended power settings.
 - ◀ Use of the wrong cartridges or excessively high power settings may lead to premature failure of the tool.

6.3 Servicing the tool

- ▶ Service the tool in the following situations:
 - ◀ If power fluctuations occur.
 - ◀ If cartridge misfires occur.
 - ◀ If the tool becomes noticeably less easy to operate.
 - ◀ If the required contact pressure increases noticeably.
 - ◀ If the trigger resistance increases.
 - ◀ If the power regulation wheel is stiff.
 - ◀ If the cartridge strip is difficult to remove.
 - ◀ If the maintenance indicator shows that a tool service is necessary.

6.4 Dismantling the single-fastener tool

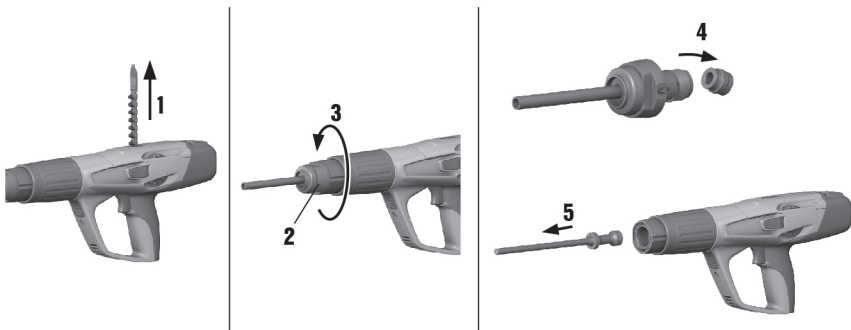

1. Check that there is no cartridge strip or fastener in the tool. If there is a cartridge strip or fastener in the tool, pull the cartridge strip up out of the tool by hand from above and remove the fastener from the fastener guide.
2. Press the release button on the side of the fastener guide to unscrew the fastener guide.

3. Unscrew and remove the exhaust gas piston return unit.
4. Remove the buffer by bending it sharply out of the fastener guide. Remove the buffer.
5. Remove the piston.

6.5 Dismantling the magazine tool

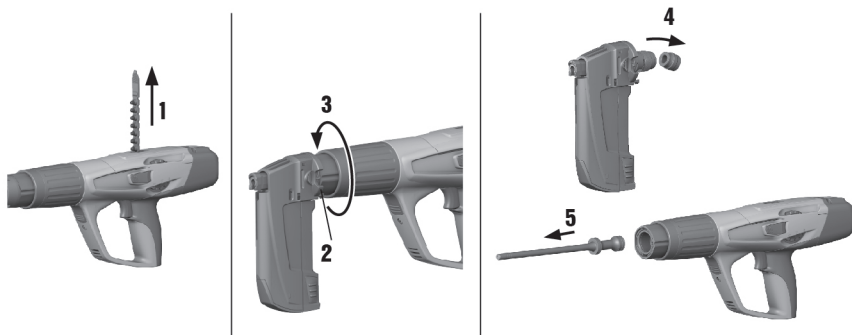

1. Check that there is no cartridge strip or fastener in the tool. If there is a cartridge strip or fastener in the tool, pull the cartridge strip up out of the tool by hand from above and remove the fastener from the fastener guide.
2. Press the release button on the side of the fastener guide to unscrew the magazine.
3. Unscrew and remove the exhaust gas piston return unit.
4. Remove the buffer by bending it sharply out of the magazine. Remove the buffer.
5. Remove the piston.

6.6 Check of buffer and piston

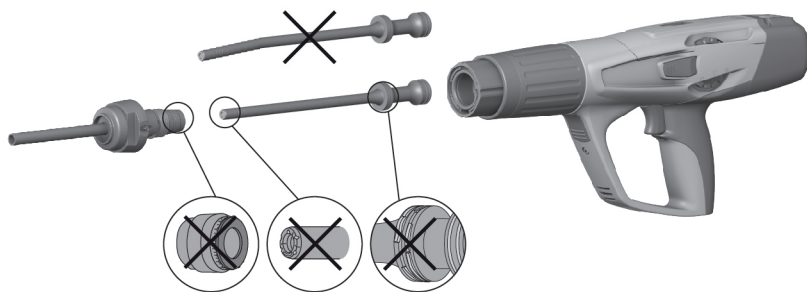

WARNING

Risk of injury caused by defective buffer or piston. Check the piston and buffer for wear and replace them if damaged.

- ▶ Do not tamper with or modify the piston.

1. The piston must be replaced in the following cases:
 - ◀ The piston is broken.
 - ◀ The piston is badly worn or chipped (e.g. a 90° segment broken away)
 - ◀ The piston rings are cracked or missing.
 - ◀ The piston is bent (check by rolling the piston on a smooth, flat surface).
2. The buffer must be replaced in the following cases:
 - ◀ The metal ring of the buffer is loose or broken.

- ◀ The buffer no longer holds on the fastener guide.
- ◀ The rubber is badly worn at certain points under the metal ring.

6.7 Checking the fastener guide for wear

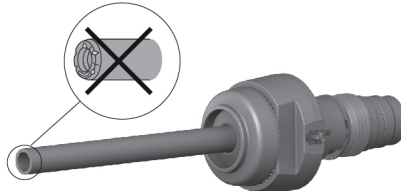

1. Check the fastener guide for wear and replace it if part of it is damaged (e.g. broken, bent, widened or cracked).
2. Contact **Hilti** Service if necessary.

6.8 Cleaning and lubricating the single-fastener tool

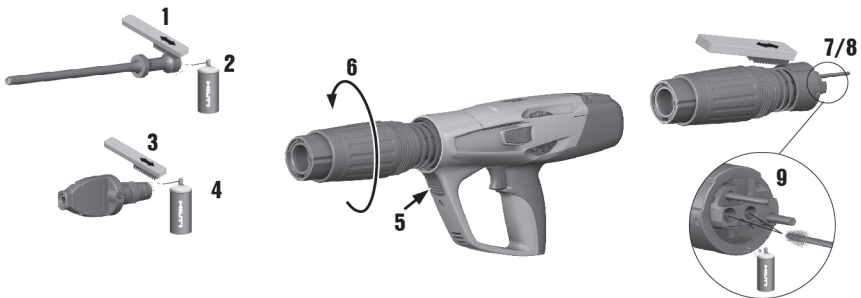

1. Spray the piston rings lightly with oil and then use the flat brush to clean them using the flat brush until the rings are free to move.
2. Use the flat brush to clean the thread on the fastener guide.
3. Use the large round brush to clean the inside of the housing.

4. Dismantle the exhaust gas piston return unit.
5. Clean the exhaust gas piston return unit.
6. Spray the cleaned parts with the supplied **Hilti** lubricant spray.

i Use only **Hilti** lubricant spray or a product of comparable quality. Use of other lubricants may damage the tool.

7. Fit the exhaust gas piston return unit.
8. Assemble the tool.

6.9 Cleaning and lubricating the magazine tool



1. Spray the piston rings lightly with oil and then use the flat brush to clean them using the flat brush until the rings are free to move.
2. Use the flat brush to clean the thread on the fastener guide.
3. Use the large round brush to clean the inside of the housing.
4. Dismantle the exhaust gas piston return unit.
5. Clean the exhaust gas piston return unit.
6. Spray the cleaned parts with the supplied **Hilti** lubricant spray.

i Use only **Hilti** lubricant spray or a product of comparable quality. Use of other lubricants may damage the tool.

7. Fit the exhaust gas piston return unit.
8. Assemble the tool.

6.10 Assembling the single-fastener tool

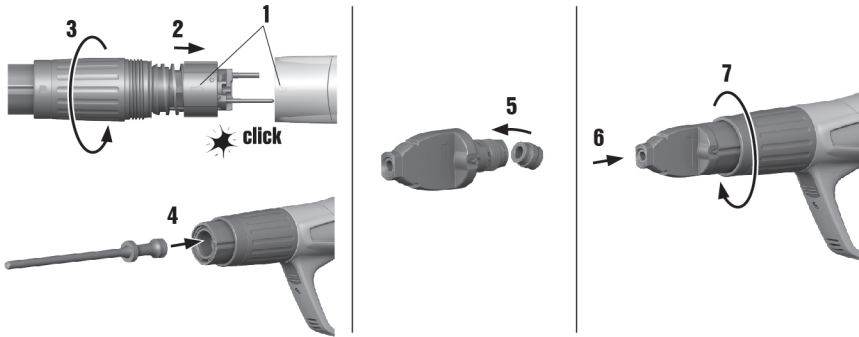

1. Check whether there is a cartridge in the tool, and remove it if there is.
2. Fit the exhaust gas piston return unit.
3. Fit the piston.
4. Fit the buffer onto the fastener guide.
5. Screw on the fastener guide.

6.11 Assembling the magazine tool

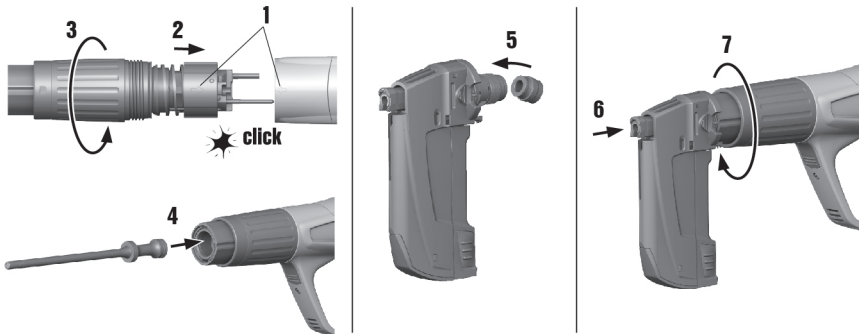





1. Check whether there is a cartridge in the tool, and remove it if there is.
2. Fit the exhaust gas piston return unit.
3. Fit the piston.
4. Fit the buffer onto the fastener guide.
5. Screw on the fastener guide.

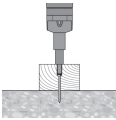
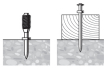

6.12 Final check of the tool

1. After carrying out care and maintenance work, check that all safety devices are fitted and that they are functioning correctly.
2. After checking the tool, press and hold the pushbutton for 10 - 12 seconds to reset the maintenance counter.

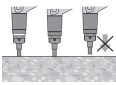

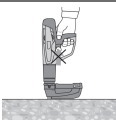
7 Troubleshooting

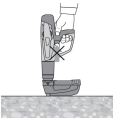

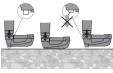
7.1 Problems with the tool

Malfunction	Possible cause	Action to be taken
 <p>The piston gets stuck in the base material.</p>	The fastener is too short.	► Use a longer fastener.
	The fastener has no washer.	► Use a fastener with washer for applications on wood.
	Driving power is too high.	<ul style="list-style-type: none"> ► Reduce driving power (adjust the power regulating wheel). ► Use a less powerful cartridge. ► Use the nails with a "top hat". ► Use the nails with a washer.
Higher force required to press the tool against the surface.	Build-up of combustion residues.	► Service the tool.
Trigger resistance increases.	Build-up of combustion residues.	► Service the tool.
Stiff movement of power regulation wheel.	Build-up of combustion residues.	► Service the tool.
 <p>The fastener is not driven deep enough.</p>	The piston is incorrectly positioned.	<ul style="list-style-type: none"> ► Remove the cartridge strip and clean the tool. ► Check the piston and buffer and replace if necessary.
	Bad cartridge.	► Pull the cartridge strip through to the next cartridge.
 <p>The piston jams in the exhaust gas piston return unit.</p>	The piston is damaged.	► Change the piston.
	Rubber dust or debris in the piston return unit.	<ul style="list-style-type: none"> ► Check the piston and buffer and replace if necessary. ► Contact Hilti Service if the problem persists.
	Build-up of combustion residues.	► Service the tool.
 <p>The exhaust gas piston return unit jams.</p>	Build-up of combustion residues.	► Service the tool.
 <p>No fastener driven: The tool fires, but no fastener is driven.</p>	The piston is incorrectly positioned.	<ul style="list-style-type: none"> ► Remove the cartridge strip and clean the tool. ► Check the piston and buffer and replace if necessary.
	 <p>The tool cannot be fired.</p>	The tool was not pressed fully against the working surface.
	The magazine is not loaded.	► Load the magazine.
	Plastic fragments in the magazine.	► Open the magazine, remove the nail strip and plastic fragments.
	The piston is incorrectly positioned.	<ul style="list-style-type: none"> ► Remove the cartridge strip and clean the tool. ► Check the piston and buffer and replace if necessary.

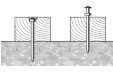
Malfunction	Possible cause	Action to be taken
 <p>The tool cannot be fired.</p>	Nails in the magazine are not correctly positioned.	<ul style="list-style-type: none"> ▶ Reload the tool.
 <p>The piston jams in the fastener guide.</p>	The piston and/or buffer are damaged.	<ul style="list-style-type: none"> ▶ Unscrew the magazine, check the piston and buffer and replace if necessary.
	Plastic fragments in the magazine.	<ul style="list-style-type: none"> ▶ Open the magazine, remove the nail strip and plastic fragments.
	Use of excessively high driving power on steel.	<ul style="list-style-type: none"> ▶ Reduce the driving power.
 <p>The fastener guide in the magazine jams.</p>	Firing the tool at a high power setting without a fastener loaded.	<ul style="list-style-type: none"> ▶ Avoid firing the tool without a fastener loaded.
	The magazine is damaged.	<ul style="list-style-type: none"> ▶ Replace the magazine.

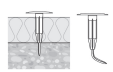
7.2 Problems with fasteners to be driven into concrete

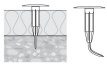
Malfunction	Possible cause	Action to be taken
 <p>Fastener driving depth varies.</p>	The piston is incorrectly positioned.	<ul style="list-style-type: none"> ▶ Remove the cartridge strip and clean the tool. ▶ Check the piston and buffer and replace if necessary.
	The tool has too much built-up dirt and residues.	<ul style="list-style-type: none"> ▶ Service the tool. ▶ If necessary, have the tool checked by Hilti Service.
 <p>The fastener bends.</p>	Hard surface (steel, concrete).	<ul style="list-style-type: none"> ▶ Increase driving power (adjust power regulating wheel).
	Hard aggregates in concrete	<ul style="list-style-type: none"> ▶ Use a more powerful cartridge. ▶ Use the single-fastener tool instead of the magazine tool.
	A rebar is located just below the concrete surface.	<ul style="list-style-type: none"> ▶ Use a shorter nail. ▶ Use a nail with a higher application limit. ▶ Drive the fastener in at a different position.
 <p>The fastener is not driven flush.</p>	Wrong fastener.	<ul style="list-style-type: none"> ▶ Use a fastener of the correct length for the insulation thickness.
	Wrong power setting.	<ul style="list-style-type: none"> ▶ Adjust the power setting on the tool.
	Hard aggregates in concrete	<ul style="list-style-type: none"> ▶ Use a more powerful cartridge. ▶ Use the single-fastener tool instead of the magazine tool.

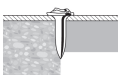

Malfunction	Possible cause	Action to be taken
 The fastener is not driven flush.	A rebar is located just below the concrete surface.	<ul style="list-style-type: none"> ▶ Use a shorter nail. ▶ Use a nail with a higher application limit. ▶ Drive the fastener in at a different position.
	Hard surface (steel, concrete).	<ul style="list-style-type: none"> ▶ Increase driving power (adjust power regulating wheel).
 Concrete spalling.	Hard/old concrete.	<ul style="list-style-type: none"> ▶ Driving threaded studs: Spall stop: X-SS...
	Hard aggregates in concrete	<ul style="list-style-type: none"> ▶ Use a more powerful cartridge. ▶ Use the single-fastener tool instead of the magazine tool.
 Damaged fastener head.	Driving power is too high.	<ul style="list-style-type: none"> ▶ Reduce driving power (adjust the power regulating wheel). ▶ Use a less powerful cartridge. ▶ Use the nails with a "top hat". ▶ Use the nails with a washer.
	The wrong piston has been fitted.	<ul style="list-style-type: none"> ▶ Check that the right combination of piston and fastener is used.
	The piston is damaged.	<ul style="list-style-type: none"> ▶ Change the piston.

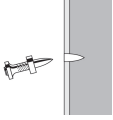
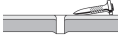

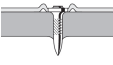
7.3 Problems with fasteners to be driven into steel

Malfunction	Possible cause	Action to be taken
 Damaged fastener head.	Driving power is too high.	<ul style="list-style-type: none"> ▶ Reduce driving power (adjust the power regulating wheel). ▶ Use a less powerful cartridge. ▶ Use the nails with a "top hat". ▶ Use the nails with a washer.
	The wrong piston has been fitted.	<ul style="list-style-type: none"> ▶ Check that the right combination of piston and fastener is used.
	The piston is damaged.	<ul style="list-style-type: none"> ▶ Change the piston.
 The fastener doesn't penetrate deep enough.	Driving power is too low.	<ul style="list-style-type: none"> ▶ Increase driving power (adjust power regulating wheel). ▶ Use a more powerful cartridge.
	The application limits have been exceeded (very hard material).	<ul style="list-style-type: none"> ▶ Use a nail with a higher application limit. ▶ Use the single-fastener tool instead of the magazine tool. ▶ Use shorter nails.
	The system is unsuitable.	<ul style="list-style-type: none"> ▶ Use a more powerful system , e.g. DX 76 (PTR).
 The fastener doesn't hold in the base material.	Thin supporting steel (4-5 mm).	<ul style="list-style-type: none"> ▶ Use a different power setting or different cartridge power level. ▶ Use a nail suitable for thin supporting steel.

Malfunction	Possible cause	Action to be taken
 Fastener breakage.	Driving power is too low.	<ul style="list-style-type: none"> ▶ Increase driving power (adjust power regulating wheel). ▶ Use a more powerful cartridge.
	The application limits have been exceeded (very hard material).	<ul style="list-style-type: none"> ▶ Use a nail with a higher application limit. ▶ Use the single-fastener tool instead of the magazine tool. ▶ Use shorter nails.
	Driving power is too high.	<ul style="list-style-type: none"> ▶ Reduce driving power (adjust the power regulating wheel). ▶ Use a less powerful cartridge. ▶ Use the nails with a "top hat". ▶ Use the nails with a washer.
 The head of the fastener perforates the fastened material.	Driving power is too high.	<ul style="list-style-type: none"> ▶ Reduce driving power (adjust the power regulating wheel). ▶ Use a less powerful cartridge. ▶ Use the nails with a "top hat". ▶ Use the nails with a washer.

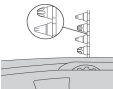
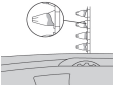
7.4 Problems with the cartridges

Malfunction	Possible cause	Action to be taken
 The cartridge strip doesn't advance.	The cartridge strip is damaged.	▶ Change the cartridge strip.
	The tool has too much built-up dirt and residues.	<ul style="list-style-type: none"> ▶ Service the tool. ▶ If necessary, have the tool checked by Hilti Service.
	The tool is damaged.	▶ If the problem persists, contact Hilti Service.
 The cartridge strip cannot be removed.	The tool has overheated.	<ul style="list-style-type: none"> ▶ Allow the tool to cool down. ▶ Then, carefully remove the cartridge strip from the tool. ▶ If the problem persists, contact Hilti Service.
 The cartridge doesn't fire.	Bad cartridge.	▶ Pull the cartridge strip through to the next cartridge.
	The tool is fouled with combustion residues.	▶ Service the tool.
 The cartridge strip melts.	The tool is pressed against the working surface for too long before firing.	<ul style="list-style-type: none"> ▶ Fire the tool sooner after pressing it against the working surface. ▶ Remove the cartridge strip.
	The fastener driving rate is too high.	<ul style="list-style-type: none"> ▶ Stop using the tool immediately. ▶ Remove the cartridge strip and allow the tool to cool.

Malfunction	Possible cause	Action to be taken
 <p data-bbox="135 236 353 276">A cartridge detaches itself from the cartridge strip.</p>	<p data-bbox="400 108 656 148">The fastener driving rate is too high.</p>	<ul style="list-style-type: none"> <li data-bbox="712 108 1011 132">▶ Stop using the tool immediately. <li data-bbox="712 135 1011 172">▶ Remove the cartridge strip and allow the tool to cool.
 <p data-bbox="135 411 378 451">The cartridge strip cannot be removed.</p>	<p data-bbox="400 292 678 308">Build-up of combustion residues.</p>	<ul style="list-style-type: none"> <li data-bbox="712 292 880 308">▶ Service the tool.

7.5 Other malfunctions

If the trouble you are experiencing is not listed in this table or you are unable to remedy the problem by yourself, please contact **Hilti** Service.

8 Disposal

 Most of the materials from which **Hilti** tools and appliances are manufactured can be recycled. The materials must be correctly separated before they can be recycled. In many countries, your old tools, machines or appliances can be returned to **Hilti** for recycling. Ask **Hilti** Service or your Hilti representative for further information.

9 Manufacturer's warranty

- ▶ Please contact your local **Hilti** representative if you have questions about the warranty conditions.

10 Confirmation of C.I.P. testing

The following applies to C.I.P. member states outside the EU and EFTA judicial area: The **Hilti** DX 5 has been system and type tested. As a result, the tool bears the rectangular PTB approval mark showing approval number S 995. **Hilti** thus guarantees compliance with the approved type. Unacceptable defects or deficiencies, etc. determined during use of the tool must be reported to the person responsible at the approval authority (PTB) and to the Office of the Permanent International Commission (C.I.P.).



Hilti Aktiengesellschaft
Feldkircherstraße 100
9494 Schaan | Liechtenstein

DX 5 (01)

[2016]

2006/42/EC

EN ISO 12100

2011/65/EU

EN 15895

Schaan, 05/2017

A handwritten signature in black ink, appearing to read "N. Wohlwend".

Norbert Wohlwend

Head of Quality Management
Business Unit Direct Fastening

A handwritten signature in black ink, appearing to read "Lars Taenzer".

Dr. Lars Taenzer

Head of BU Direct Fastening
Business Unit Direct Fastening



Hilti Corporation
LI-9494 Schaan
Tel.: +423 234 21 11
Fax: +423 234 29 65
www.hilti.group



2164701



Hilti Connect